

FVZ 240-300 6X4
FVY 240-300 6X4



Truck images shown may vary from actual model specification - Contact Isuzu for further details

WEIGHT RATINGS*

GVM 24,000 kg
GCM 36,000 kg

ENGINE

POWER 221 kW @ 2,400 rpm
TORQUE 981 Nm @ 1,450 rpm

TRANSMISSION

9 speed manual transmission (MT)
6 speed automatic transmission (AT)

* Refer to back page for detailed weight rating information

ISUZU CARE	
WARRANTY	6 Year Standard Warranty
	500,000 km / 8,000 Engine Hours
ROADSIDE ASSIST	6 Year Roadside Support
	24/7 Unlimited km
HARSH APPLICATION WARRANTY (CONCRETE AGITATOR / GARBAGE COMPACTOR)	3 Year Standard Warranty
	200,000 km / no hours stipulation
	3 Year Roadside Support
	24/7 Unlimited km

SERVICE AGREEMENTS			
OPTIONAL SERVICE PACKAGES	ESSENTIALS	ESSENTIALS PLUS	TOTAL
SCHEDULED SERVICINGS	●	●	●
CONSUMABLES		●	●
ENGINE, TRANSMISSION & DRIVELINE			●
EXTRAS	After-hours Servicing, Glass, Fuel Card, Pickup - Dropoff		

INTELLIGENT SAFETY		
ACTIVE SAFETY	Electronic Stability Control	(ESC)
	Anti Lock Braking System	(ABS)
	Anti Skid Regulator	(ASR)
	Electronic Braking System	(EBS)
	Hill Start Aid - except AT models	(HSA)
	Cab Tilt Warning	(CTW)
	Low light capable reversing camera	
PASSIVE SAFETY CABIN OCCUPANT SAFETY SYSTEMS (COSS)	Driver & front passenger airbags	
	Driver & front left hand passenger seatbelt pretensioners	
	ECE-R29 cab with side anti-intrusion beams	
	Door mounted cornering lamps	



Subject to the conditions outlined in the IAL New Vehicle Warranty. For further information please visit isuzu.com.au or contact your local dealer.

ENGINE	
DESCRIPTION	Isuzu 6HK1-TCS
TYPE	6 cylinder 24 valve SOHC
DISPLACEMENT	7,790 cc
COMPRESSION RATIO	17.5:1
BORE X STROKE	115mm x 125mm
POWER	221kW (300PS) @ 2,400 RPM (DIN NET)
TORQUE	981Nm @ 1,450 RPM (DIN NET)
INDUCTION	Electronically controlled variable nozzle turbocharger with air-to air intercooler.
FUEL INJECTION	Direct injection high pressure common rail system.
EMISSION CONTROL	Cooled EGR with exhaust Diesel Particulate Diffuser (DPD). ADR 80/03 (Euro V / EEV) compliant.

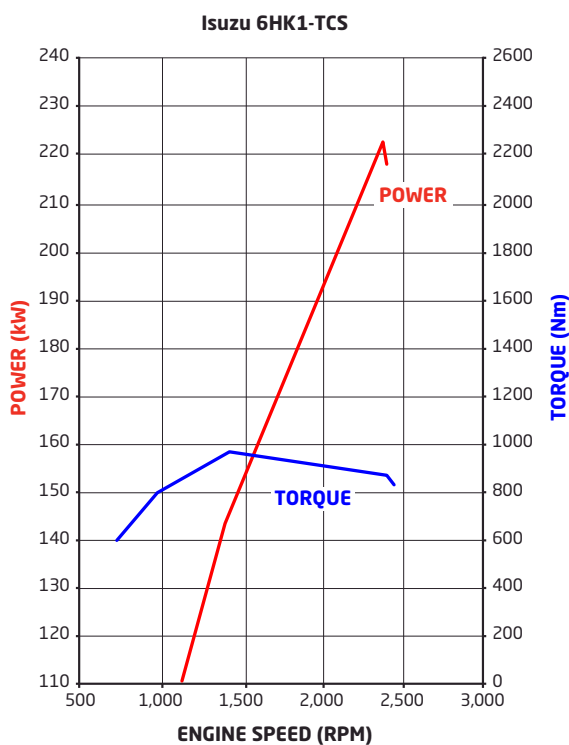

TRANSMISSION		
MT	CLUTCH	Type: Single plate with air assisted hydraulic control Clutch plate diameter: 381 mm Clutch lining area: 1,363 cm ²
	GEARBOX	Description: ZF 9S 1110 TO Type: 9 speed with synchromesh on gears 1-8
		Ratios: Crawler 1st 2nd 3rd 4th 5th 6th 7th 8th Rev 9.48 6.58 4.68 3.48 2.62 1.89 1.35 1.00 0.75 8.97
		Power Take Off facility: Provision at rear of transmission case
		Other features: Repeat 'H' shift pattern
AT	Description: Allison 3500 Type: 6 speed automatic	
	Ratios: 1st 2nd 3rd 4th 5th 6th Rev 4.59 2.25 1.54 1.00 0.75 0.65 5.00	
	Power Take Off facility: LHS and top openings on transmission bellhousing. Engine driven PTO drive gear.	
	Other features: 5th generation electronic controls with adaptive shift. Long life TranSynd synthetic fluid.	

AXLES		
FRONT	Description:	Meritor FG941
	Type:	Reverse Elliot I-beam
	Capacity:	6,600 kg
REAR	Description:	Meritor MT40-144GP (MT models)
		Meritor MT44-144GP (AT models)
	Type:	Tandem drive
	Other Features:	Inter-axle lock & cross locks fitted to both axles
	Capacity:	20,000 kg
Ratio:	MT: 6.142, AT: 6.428	

SUSPENSION		
FRONT	Type:	Single stage alloy steel taper-leaf springs
	Other features:	Double acting hydraulic shock absorbers. Stabiliser bar.
REAR	FVZ Type:	Multi-leaf springs with Isuzu 6 rod and trunnion location system
	FVY Description:	Hendrickson HAS460
	FVY Type:	Airbag
FVY Capacity:	18,100 kg at ground	

BRAKES	
DESCRIPTION	Meritor 'Q-Plus'
TYPE	Full air 'S-Cam' front & rear drum brakes
DIAMETER X WIDTH FRONT	419 x 127 mm
DIAMETER X WIDTH REAR	419 x 178 mm
PARK BRAKE	Spring park brake acting on all rear wheels
AUXILIARY BRAKE	Air controlled exhaust brake

STEERING	
TYPE	Power assisted recirculating ball
GEAR RATIO	22.4:1
TURNS LOCK TO LOCK	5.4
WHEEL LOCK ANGLE	45° (inside wheel) / 35° (outside wheel)

WHEELS & TYRES			
FRONT	Wheels:	22.5 x 8.25 ten stud ISO standard steel wheels (except FVY AUTO MWB)	
		22.5 x 8.25 ten stud ISO standard polished Alcoa aluminium wheels (FVY AUTO MWB)	
	Tyres:	295/80R22.5 152/148M Michelin X Multi Z Tubeless	
	Steer axle tyre rating	7,100 kg	
REAR	Wheels:	22.5 x 8.25 ten stud ISO standard steel wheels (except FVY AUTO MWB)	
		22.5 x 8.25 ten stud ISO standard polished Alcoa aluminium wheels (FVY AUTO MWB)	
	Tyres:	11R22.5 148/145L Michelin X Multi D Tubeless	
	Tandem axle tyre rating:	23,200 kg	
Spare: Spare wheel and X Multi Z tyre assembly supplied. Winch type carrier (except FVZ MWB and FVY MWB).			

CHASSIS FRAME	
TYPE	Cold rivetted ladder frame with parallel side rails.
MATERIAL	MWB / MLWB: HT540A LWB: SAPH440
DIMENSIONS	MWB / MLWB: Side rail (mm): 254 x 85 x 8.0 Rear frame width (mm): 850 LWB: Side rail (mm): 258 x 85 x 10.0 Rear frame width (mm): 850

FUEL TANK	
TYPE	Frame mounted steel fuel tank (except FVZ LWB & FVY LWB models with MT) Frame mounted aluminium fuel tank (FVZ LWB & FVY LWB models with MT)
CAPACITY	200L (except FVZ LWB & FVY LWB models with MT) 400L (FVZ LWB & FVY LWB models with MT)
FUEL CAP	Lockable

ELECTRICAL SYSTEM	
TYPE	24 volt
ALTERNATOR	90 amp
STARTER MOTOR	5.0 kW
BATTERY	2 x 115E41L (651 CCA) batteries connected in series
CAN BUS PROVISION	Underdash CAN system access plug for connection to a Fleet Management System (FMS) (not supplied)

CABIN SPECIFICATIONS & APPOINTMENTS

CABIN GENERAL FEATURES	
ENGINE ACCESS	Electro-hydraulic cab tilt
CAB MOUNTING	Rear coil spring suspension with hydraulic shock absorbers
STEPS	Heavy duty anti slip steps
DOORS	90° opening internally reinforced front doors
MIRRORS	Heated & powered exterior main mirrors with flat glass and additional independantly adjustable convex "spot" mirrors
WIPERS	Two speed windscreen wipers with intermittent wipe mode
EXTERIOR LIGHTING	LED main beam and halogen high beam headlamp assembly with position lamp Roof mounted clearance lamps Front foglamps
AUDIBLE WARNING	Reverse alarm
GRILLE	Chrome
FRONT BUMPER	Body coloured air dam type
SECURITY	Central locking with remote keyless entry & immobiliser

CABIN INTERIOR	
SEATING	Isri 6860/875 NTS air suspension driver's seat
SEATBELTS	3-point lap sash seatbelts in all outboard seating positions. Driver seatbelt integrated with driver seat. Centre seat lap belts.
STEERING COLUMN	Tilt/telescopic adjustable
ENTRY ASSIST GRIPS	Door & roof pillar mounted
DOOR WINDOWS	Electric control
STORAGE	Overhead compartments Twin cup holders Centre console box & storage tray Front door pockets
POWER OUTLET	24V cigarette lighter
AIRCONDITIONING	Auto control
INTERIOR LIGHTING	Fluorescent lamp
REAR COMPARTMENT	ADR 42 compliant sleeper with mattress

MYISUZU CO-PILOT AUDIO VISUAL UNIT	
SCREEN TYPE	10.1" 1080p High Definition with capacitive touch
OPERATING SYSTEM	Android Automotive
RADIO	AM/FM/DAB+
INTERNAL STORAGE CAPACITY	32GB
SMARTPHONE INTEGRATION	USB 3.0 socket Wi-Fi connectivity Android Auto / Apple CarPlay compatible Phone storage pocket with wireless charging facility

DRIVER CONTROLS	
SAFETY SYSTEMS	ESC on/off, HSA on/off/sensitivity adjust (except AT models)
ENGINE	Idle speed control Cruise control DPD manual regeneration switch
TRANSMISSION (AT ONLY)	Pushbutton gear selection control
GENERAL CONTROLS	Headlamp on/off and levelling, windscreen wipers (2 speed and intermittent modes), washers, exhaust brake, turn signals Inter-axle and cross lock engage switches

INSTRUMENTATION	
MULTI INFORMATION DISPLAY	CTW indicator Low engine oil level alert Vehicle systems status Low fuel level alert Fuel consumption information Service interval alerts Hourmeter Adjustable vehicle speed warning
GENERAL INSTRUMENTATION	Speedometer & tachometer Digital odometer with integrated dual tripmeters Engine coolant temperature, fuel level and air pressure guages

WEIGHTS (kg)							
MODELS	RATINGS*		LOADING LIMIT* (at ground)		CAB CHASSIS WEIGHT #		
	GVM	GCM	FRONT	REAR	FRONT	REAR	TOTAL
FVZ 240-300 MWB	24,000	36,000	6,600	20,000	3,290	3,395	6,685
FVZ 240-300 AUTO MWB	24,000	36,000	6,600	20,000	3,370	3,405	6,775
FVZ 240-300 AUTO MLWB	24,000	36,000	6,600	20,000	3,475	3,440	6,915
FVZ 240-300 LWB	24,000	36,000	6,600	20,000	3,545	3,640	7,185
FVY 240-300 AUTO MWB (AW)	24,000	36,000	6,600	18,100	3,425	3,085	6,510
FVY 240-300 LWB	24,000	36,000	6,600	18,100	3,545	3,440	6,985
FVY 240-300 AUTO LWB	24,000	36,000	6,600	18,100	3,595	3,420	7,015

* Vehicle ratings and front/rear weight limits are subject to government regulatory requirements and weight distribution analysis. Consult your Isuzu dealer to select the correct vehicle for your specific application.

Cab chassis only as supplied and including 10 litres of fuel.

DIMENSIONS (mm)													
MODELS	WB	OAL	FOH	ROH	EA	CE	RT	ORT	CH	FFA (unladen)	RFA (unladen)	RFH (unladen)	TURNING CIRCLE KERB TO KERB (m)
FVZ 240-300 MWB / AUTO MWB	4,410	7,605	1,440	1,755	3,710	5,540	1,840	2,445	2,850	1,000	1,075	1,090	15.4
FVZ 240-300 AUTO MLWB	5,300	9,180	1,440	2,440	4,600	7,115	1,840	2,445	2,850	1,000	1,075	1,080	18.5
FVZ 240-300 LWB	6,470	11,150	1,440	3,240	5,770	9,085	1,840	2,445	2,850	1,000	1,065	1,095	22.6
FVY 240-300 AUTO MWB	4,410	7,605	1,440	1,755	3,710	5,540	1,840	2,445	2,810	1,000	1,015	1,015	15.4
FVY 240-300 LWB / AUTO LWB	6,470	11,150	1,440	3,240	5,770	9,085	1,840	2,445	2,850	1,000	1,020	1,025	22.6

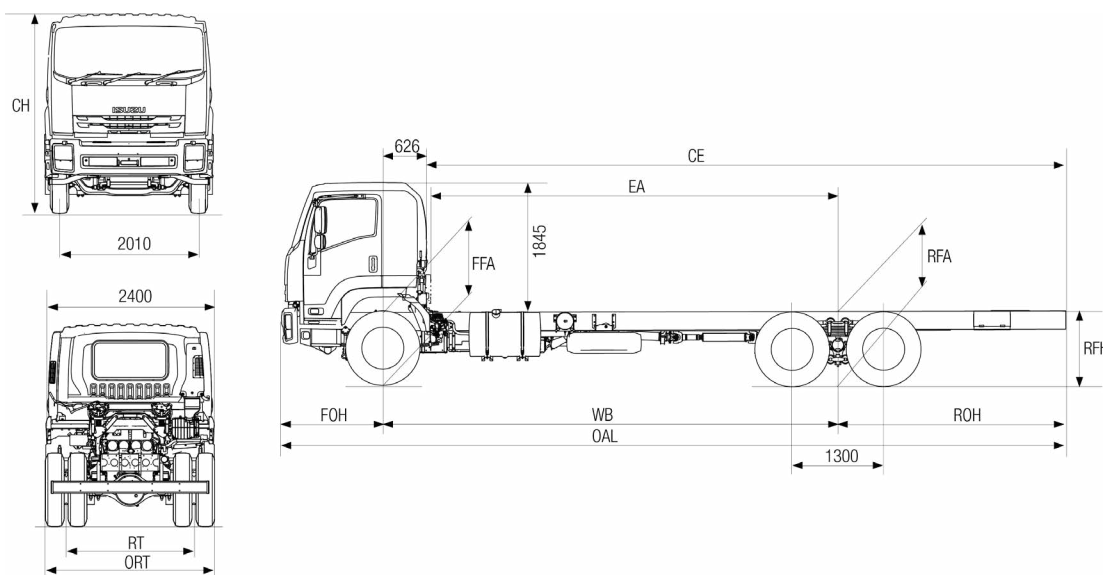

PERFORMANCE (calculated - typical paved road)				
		GEARED SPEED~ (top gear at peak power engine rpm)	LOW SPEED GRADEABILITY (lowest forward gear assuming no wheel slip)	ENGINE SPEED (top gear at 100 km/h)
FVZ/FVY 240-300	at 24,000 kg GVM	101 km/h @ 2,400 rpm	41%	2,380 rpm
FVZ/FVY 240-300 AUTO	at 24,000 kg GVM	111 km/h @ 2,400 rpm	41%	2,160 rpm

* Maximum speed achievable depends on vehicle frontal area as well as other factors. Consult your Isuzu dealer for more detailed information. Vehicle is speed limited to 100km/h.

ORDER CODES	
Models	Codes
FVZ 240-300 MWB	FH-FVZJZ-B22
FVZ 240-300 AUTO MWB	FH-FVZJZ-L22
FVZ 240-300 AUTO MLWB	FH-FVZJZ-M22
FVZ 240-300 LWB	FH-FVZJZ-D22
FVY 240-300 AUTO MWB (AW)	FH-FVYJZ-L22
FVY 240-300 LWB	FH-FVYJZ-D22
FVY 240-300 AUTO LWB	FH-FVYJZ-N22

Subject to the conditions outlined in the IAL New Vehicle Warranty, Isuzu F series models carry a standard factory warranty which covers the owner for the first 72 months or 500,000 kilometres or 8,000 Engine Hours (whichever comes first). All Isuzu warranties are subject to mandatory prescribed terms under Australian Consumer Law including consumer guarantees. Harsh Conditions variations to standard factory warranty may apply. For more details visit the Isuzu website at www.isuzu.com.au which explains Isuzu warranties in more detail, or alternatively contact your local Isuzu Truck dealer. All warranties commence from date of initial delivery.

ISUZU AUSTRALIA LIMITED ABN 97 006 962 572 ("IAL"). The information in this spec sheet was correct at time of printing, but all measurements, specifications and equipment are subject to change without notice. Some equipment may have been changed and/or is available at extra cost. IAL may make changes at any time without notice, in prices, colours, materials, equipment and models. IAL makes all reasonable attempts to ensure the availability of all vehicles and equipment. The information in this spec sheet is general in nature. Your Isuzu dealer can confirm all measurements, specifications and vehicle / equipment availability upon request. To the extent permitted by the law, IAL is not liable to any person as result of reliance on the content of this spec sheet.